



Weather Adaptive Helmet

Hetal Shah*, Narendrakumar Chauhan, Vageshri Jhala and Parul Sharma

Department of Electronics Engineering, Faculty of Technology, Dharmsinh Desai University, Nadiad, Gujarat, India
shahhetal.ec@ddu.ac.in

Available online at: www.isca.in, www.isca.me

Received 25th July 2024, revised 11th November 2024, accepted 22nd December 2024

Abstract

In the realm of motorcycle safety, helmets have undergone significant advancements, incorporating features such as accident detection, SOS alerts, and alcohol detection to enhance rider safety. However, in the diverse and extreme seasonal variations of the Indian subcontinent, additional challenges arise. To address these challenges, we introduce the Weather-Adaptive Smart Helmet, a smart concept. This innovative helmet offers three fundamental solutions for rider safety and comfort. It is equipped with an automatic light-resistant visor, ensuring optimal vision and eye protection during intense sunlight and scorching heat waves. The helmet also includes an efficient ventilation system, maintaining riders' comfort by optimizing airflow, regardless of weather conditions. In monsoon conditions, a detachable rain cover deploys automatically upon detecting rainfall, safeguarding the rider's possessions. The primary goal of this system is to enhance the two-wheeler riding experience, giving riders the confidence to navigate diverse weather conditions while prioritizing their safety and comfort.

Keywords: Helmet, Light-resistant vision, Ventilation, Rain cover.

Introduction

In the realm of motorcycle safety, the helmet has evolved into an indispensable tool, designed to enhance rider safety and comfort. Advanced technologies, including accident detection, SOS alerts, and alcohol detection systems, have been integrated into these essential safety devices, thereby ensuring safer journeys on the road. Nevertheless, in the diverse and often extreme seasonal variations experienced within the Indian subcontinent, riders face unique challenges. India witnesses four distinct seasons throughout the year, each demanding adaptability, and innovative solutions to ensure rider safety and comfort. Recognizing the need to address these challenges, this research paper introduces a pioneering concept—the Weather-Adaptive Smart Helmet. This innovative helmet has been meticulously engineered to offer three fundamental solutions, each tailored to confront the specific challenges encountered during two-wheeler operation in India. It features an automatic light-resistant visor to protect against intense sunlight, an efficient ventilation system to combat discomfort caused by perspiration, and a detachable rain cover for monsoon conditions. The primary objective of this system is to elevate the standard of the two-wheeler riding experience, empowering riders with the confidence to navigate diverse weather conditions while consistently prioritizing their safety and comfort. The Weather-Adaptive Smart Helmet represents not only a technological advancement but also a safety revolution tailored for the unique challenges presented by the Indian road landscape.

Related Work: As per government mandate, it is required to wear helmet when riding two-wheeler for safety of the riders.

However, the riders avoid wearing helmet due discomfort and suffocation in hot weather conditions. To address the challenges, various innovative designs of helmets are available in the market. New ideas are also proposed in literature to design helmet with more facilities and comfort to the riders. To avoid riding without a helmet, a new helmet design was proposed that allows the bike rider to start the vehicle only when the helmet is connected via a radio frequency (RF) signal. This innovative approach enhances safety and compliance with helmet regulations¹. This helmet design has been enhanced to include a feature that automatically calls for an ambulance in the event of a road accident². Now a days bike riding is fun but the impact when motorcyclist involves in a high-speed accident without wearing helmet is very dangerous and can cause fatality. At this time something for weather adaptive helmets embedded with sensors are lifesaving gadgets. Researchers have developed low-cost smart helmet to prevent road accidents however existing helmets are not season friendly. A helmet system has been developed to issue alerts when the helmet is not worn correctly or when the rider exceeds the designated speed limit. Additionally, it provides warnings when traversing potholes or bumps at potentially hazardous speeds. This innovative design aims to enhance rider safety by proactively addressing these critical factors. Furthermore, a significant number of helmet designs presented in the literature leverage advanced technologies to provide valuable information related to road accidents³. A novel helmet design has been introduced that ensures the reliable and real-time transmission of information regarding road accidents to designated emergency contacts. This system continuously monitors the accelerator's performance using a sophisticated Wi-Fi-based processor in conjunction with cloud computing technology. By leveraging

these advanced methods, the helmet not only enhances rider safety but also facilitates prompt assistance in emergency situations⁴. A sophisticated smart helmet system has been developed to facilitate both accident detection and location tracking, effectively leveraging cloud and GPS technology for seamless operation. This advanced design not only enhances safety by providing real-time monitoring but also incorporates an embedded MQ3 sensor capable of detecting alcohol consumption by the motorcyclist. This additional feature serves to further mitigate risks on the road, promoting safer riding practices⁵. An enhanced model of the previous design has been proposed, incorporating features such as alcohol detection, accident identification, location tracking, a hands-free device, a solar-powered module, and fall detection, all of which are connected to the ignition system. In this innovative approach, the ignition will not be triggered to start the two-wheeler unless the helmet is properly worn. Additionally, to address emergency situations effectively, a GSM module is utilized to send alert messages to a registered mobile number⁶. As an application of the proposed design, this system can send an alarm in the event of an accident involving a cyclist, all while avoiding the need to place heavy or hazardous batteries on the user's head. Furthermore, it can generate energy to power smart sensor-based devices integrated into the helmet using solar energy⁷. A novel concept for a season-friendly helmet system has emerged, featuring a redesign of the industrial safety helmet's shell to enhance its thermal properties. This improvement includes the addition of ventilation holes, increased clearance between the helmet shell and the wearer's head, and the application of reactive materials to the shell. These innovations collectively aim to provide better comfort and safety in varying environmental conditions⁸. A comprehensive version of a helmet designed for sunlight protection with energy transformation has been developed. In this design, steady-state heat transfer was assessed using a thermal manikin in a wind tunnel, which facilitated the induction of a baseline for moderate convection cooling. This approach aims to enhance user comfort and safety in sunny conditions⁹. An advanced structure of a seasonable smart helmet system has been proposed, designed specifically to offer significant convenience during the rainy season. This innovative helmet features an integrated wiper system that operates with an on-off control mechanism, activated by voice commands issued by the motorcyclist. This functionality not only enhances visibility in adverse weather conditions but also promotes safer riding by allowing the rider to maintain focus on the road while managing the wiper system¹⁰.

Motivation and Contribution

From the reported work mentioned above, it is observed that considerable efforts have been made to design smart helmets. However, in tropical regions, two wheeler riders face the weather related issues due to diversity in weather conditions. In above work, no smart helmet is designed which provide protection in various weather condition. In this context, weather

adaptive helmet is design to provide protection in summer, winter, and rainy seasons. To the best of our knowledge, the design of weather adaptive helmets is not proposed in the literature. In particular, the contributions of our work are as follows. i. First our aim in this project is it effectively resolve the issues arising from intense sunlight and heat waves that directly impact the eyes. This task is well-versed by incorporating an automatic light-resistant screen that activates when exposed to high levels of sunlight. ii. Secondly, the helmet features an efficient ventilation system to combat perspiration-related discomfort during rides, ensuring optimal airflow. This ventilation providing here is given by holes. iii. Lastly, it provides a reliable rain cover specifically designed for monsoon conditions. This cover automatically deploys upon detecting rainfall, shielding the rider's bag pack from precipitation.

Paper Organization: The rest of the paper is organized as follows. Section II presents a block diagram of the weather adaptive helmet and its description. The operational working of the weather adaptive helmet is described in Section III. The proposed concept is mentioned in Section IV. Finally, the work is concluded in Section V followed by references.

System Development: System development of the weather adaptive helmet is discussed in the following block diagram and operational working.

Block Diagram: The block diagram of weather adaptive helmet is shown in Figure-2. The block diagram is divided into four major parts:

Power supply: A power supply is a fundamental component in electronic systems, serving the crucial role of providing electrical energy to electric loads. These loads encompass a wide range of devices, from household appliances to sophisticated industrial machinery. Power supplies come in two main types: AC (Alternating Current) and DC (Direct Current). Power supplies can be integrated into devices or exist as standalone units, either internal or external to the electronic system. Whether found in a personal computer or a laboratory setting, power supplies ensure that electronic devices receive the precise electrical parameters necessary for their reliable function. It fulfils the power requirement of controller board, sensors, relays and motors. Another approach to provide the power to circuit is using solar cell as a power supply.

Sensors: Sensors play a pivotal role as the vigilant eyes and attentive ears of our project, seamlessly capturing and translating real-world phenomena into valuable data. Our system relies on the integration of specific sensors, including a temperature sensor, humidity sensor, and rain sensor. The temperature sensor activates when the ambient temperature surpasses predefined limits, providing a signal for necessary actions. Simultaneously, the humidity sensor contributes by monitoring humidity levels, ensuring a comprehensive understanding of environmental conditions. Meanwhile, the rain

sensor stands ready to raise alarms at the first detection of rain droplets, offering a pre-emptive alert system. These sensors collectively form the sensory backbone of our project, enabling us to respond proactively to environmental changes and enhance the overall effectiveness of our system.

Controller board: Arduino is a prominent open-source electronics platform known for its user-friendly hardware and software components. At its core is a programmable microcontroller, typically based on Atmel AVR or ARM processors, which executes code written and uploaded through the platform’s simplified integrated development environment (IDE). Arduino’s versatility is evident in its adaptability to a broad spectrum of projects, ranging from robotics and home automation to interactive art installations. The platform’s expansion capabilities are facilitated by “shields,” hardware add-ons that enhance functionality. Arduino’s affordability, simplicity, and extensive online resources have made it a driving force in the maker and do-it-yourself (DIY) communities, democratizing electronics, and programming for enthusiasts worldwide.

Actions: The block diagram conveys the operation of a smart helmet in three major stages to address challenges faced by riders such as automatic light-resistant screen for eye protection, efficient ventilation system for comfort, and a rain cover for rain protection.

Operational Working

The operational working is divided into following four parts:
 Automatic Light-Resistant Screen: The features of a screen are designed to address intense sunlight and heat waves for rider protection. It encompasses the synchronization of the shield with temperature and light sensors to effectively mitigate adverse weather conditions. Additionally, the integration of light sensor technology enables automatic activation, contributing to user convenience. The overall focus is on enhancing eye protection for riders.

Efficient Ventilation System: The features of a ventilation system aimed at alleviating discomfort associated with perspiration during helmet use. It includes the optimization of airflow to improve overall comfort for riders. An evaluation of the system’s efficacy is conducted by integrating temperature and humidity sensors to monitor and regulate the internal temperature of the helmet.

Reliable Rain Cover for Monsoon Conditions: The development of a dedicated rain cover mechanism designed to offer optimal protection in rainy conditions. The system integrates advanced sensors for the automatic deployment of the rain cover upon rain detection. The study evaluates the cover’s effectiveness in protecting the rider’s backpack from precipitation, providing valuable insights into the design and performance of a tailored rain protection solution for motorcycle riders.

Smart solar cell for power supply: Solar cell being a smart and environment friendly is a vital approach to supply power to the circuit. When sunlight hits the solar cell, it excites electrons in the semiconductor material, causing them to move and create an electric current. This generated electricity can then be used to power various electrical devices or stored in batteries for later use.

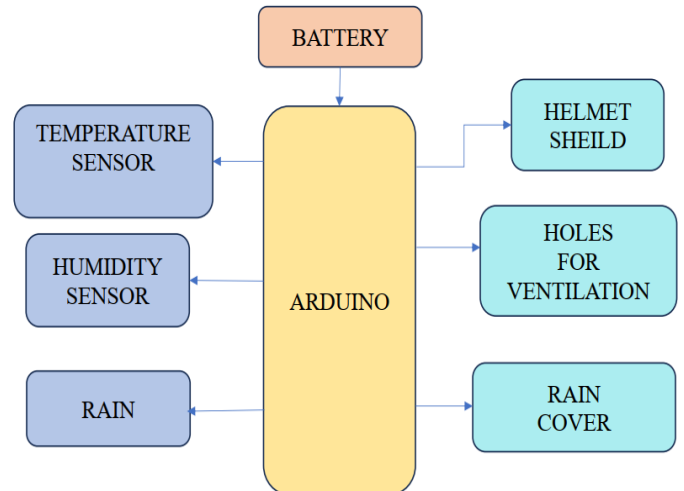

Figure-1: Block Diagram

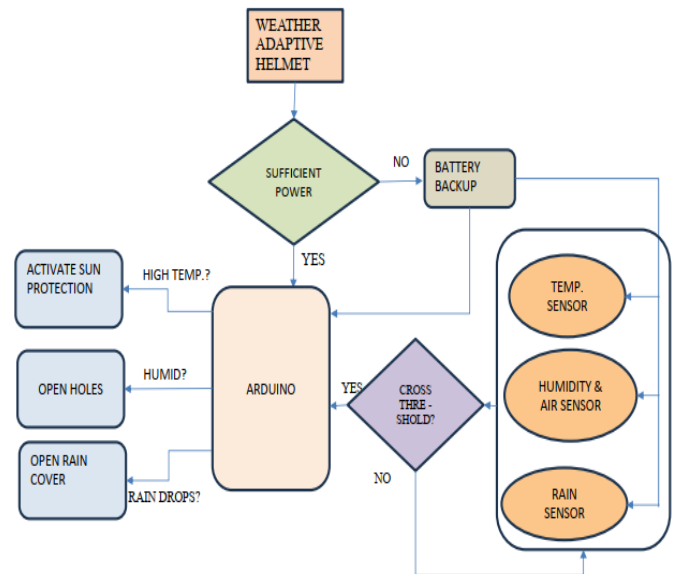

Figure-2: Flow Chart.

Proposed Concept

In our system design, we have segmented the operational framework into three distinct sensing modules. The initial module integrates temperature and light sensors, which collaborate to trigger a responsive mechanism. Specifically, when encountering elevated temperatures and intense sunlight, an automatic protective shield will deploy, shielding the eyes from potential harm.

This deployment is facilitated by motorized components linked to an Arduino controller. Similarly, to address concerns related to inadequate ventilation and heat buildup within the helmet, we propose the integration of autonomously operated valves. These valves will dynamically regulate airflow within the helmet, responding to fluctuations in internal temperature detected by a dedicated sensor. Control of the valves will be orchestrated through motor-driven mechanisms, coordinated by the Arduino platform. In addition, to mitigate the effects of rainfall, an automatic rain cover deployment system will be implemented. This system will rely on a rain sensor to detect precipitation, triggering the swift deployment of a protective cover. Notably, the synchronization of this rain cover mechanism with the temperature sensor-driven valve operation ensures that during rainy conditions, the valves remain closed, preventing unwanted ingress of water. By incorporating these sophisticated sensing blocks and responsive mechanisms, our research aims to enhance safety and comfort for riders, offering a comprehensive solution to address environmental challenges encountered during motorcycle use.

Conclusion

The development and implementation of the weather-adaptive helmet represents a significant advancement in personal safety and comfort for individuals, where climatic conditions can be highly diverse. By incorporating intelligent features such as humidity-responsive ventilation, rain protection, and automatic UV shielding, this helmet not only ensures physical well-being but also enhances the overall experience of outdoor activities. The innovation showcased in this project offers a glimpse into the future of wearable technology, where adaptive solutions seamlessly integrate with our daily lives, making them more convenient and secure. As we continue to explore new frontiers in technology and design, the weather-adaptive helmet serves as a testament to our commitment to improving the quality of life, even in the face of challenging weather conditions.

References

1. Agarwal, N., Singh, A. K., Singh, P. P., & Sahani, R. (2015). Smart helmet. *International Research Journal of Engineering and Technology*, 2(02), 3.
2. Patel, M. V. A., Mishra, M. A., Hiten, M. R., & Prajapati, M. K. (2017). Smart helmet. *Int. Res. J. Eng. Technol*, 4, 7-10.
3. Budiman, A. R., Sudiharto, D. W., & Brotoharsono, T. (2018). The prototype of smart helmet with safety riding notification for motorcycle rider. In *2018 3rd International Conference on Information Technology, Information System and Electrical Engineering (ICITISEE)* (pp. 362-367). IEEE.
4. Chandran, S., Chandrasekar, S., & Elizabeth, N. E. (2016). Konnect: An Internet of Things (IoT) based smart helmet for accident detection and notification. In *2016 IEEE Annual India Conference (INDICON)* (pp. 1-4). IEEE.
5. Dhulavvagol, P. M., Shet, R., Nashipudi, P., Meti, A. S., & Ganiger, R. (2017). Smart helmet with cloud GPS GSM technology for accident and alcohol detection. In *International Conference on Cognitive Computing and Information Processing* (pp. 346-357). Singapore: Springer Singapore.
6. Shahare, B., Chawde, S., Gudafwar, R., Pal, H., Bobade, P., & Bawankar, S. (2021). Iot Based smart motor cycle helmet. *Journal of Electronics*, 3(01), 15-22.
7. Bibbo, D., Conforto, S., Laudani, A., & Lozito, G. M. (2017). Solar energy harvest on bicycle helmet for smart wearable sensors. In *2017 IEEE 3rd International Forum on Research and Technologies for Society and Industry (RTSI)* (pp. 1-6). IEEE.
8. Hsu, Y. L., Tai, C. Y., & Chen, T. C. (2000). Improving thermal properties of industrial safety helmets. *International Journal of Industrial Ergonomics*, 26(1), 109-117.
9. Brühwiler, P. (2008). Radiant heat transfer of bicycle helmets and visors. *Journal of sports sciences*, 26(10), 1025-1031.
10. Rao, S. (2019). Voice controlled wiper for smart helmets. *International Journal of Innovative Technology and Exploring Engineering*, 8(12), 2086.